

GAS10

Single Point Gas Detector

- Flammable, Oxygen or Toxic Gases
- Compact size
- Single stage alarm
- Alarm relays
- Alarm Sounder / LED
- Digital display
- Wall or panel mount
- 4~20mA analogue output



Application:

A fixed gas sensor that meets the requirements for economic and reliable monitoring of gas levels in a wide range of environments and applications.

Initially designed for the monitoring of gases within cabins, enclosures and cabinets the addition of an optional mains supply input expanded its use into conventional areas of gas detection covering boiler plant rooms, gas meter houses, battery charger rooms and many other commercial and light industrial applications.

Technical:

Power Supply	<ul style="list-style-type: none"> • 12 to 30V DC - 24v nominal • 230/115V AC optional
Sensor Type	<ul style="list-style-type: none"> • Catalytic, Electrochemical, Infra-Red, Semiconductor, Thermal conductivity
Measuring Range	<ul style="list-style-type: none"> • Combustible gas - LEL, % vol. ppm. • Toxic gas - ppm, % vol. • Oxygen - % vol.
Output	<ul style="list-style-type: none"> • 4~20mA. Analogue option 1~5 volts

Connections

- 3 wire - sink/source or
- 2 wire - loop powered - 4~20mA output only (Oxygen/toxic gases only)

Relay contacts

- S.P.C.O. per relay - auto reset
- rated RL1 - 5A/250v AC, RL2 1A/24v DC

Alarm LED/Sounder

- Auto reset

Ingress protection

- IP65

Material

- Polycarbonate - light grey RAL 7035

Entries

- Not specified - top, bottom, sides

Dimensions

- 122 x 120 x 56 mm

Mounting

- 4 x 4mm internal fixing points
- @ 90mm horizontal x 100mm vertical

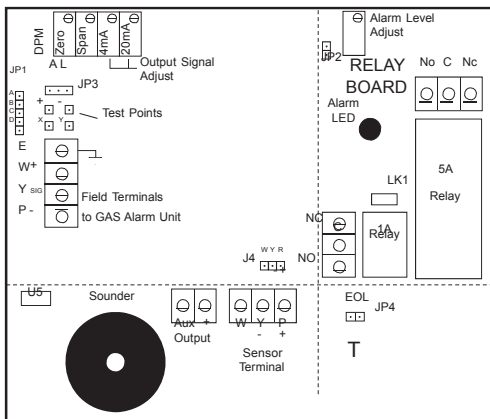

Toxic/Oxygen PCB

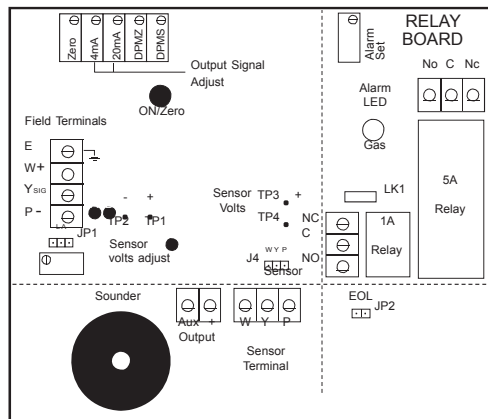

Flammable PCB

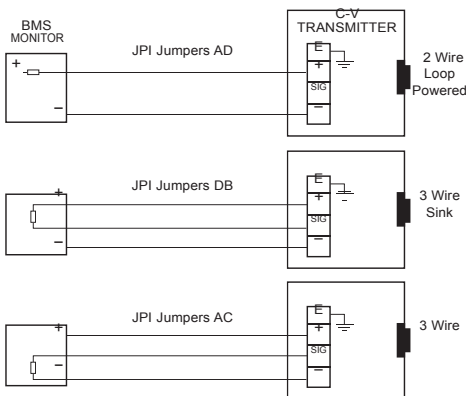

Oxygen	0~25%
Carbon Monoxide	0~250ppm
Hydrogen Sulphide	0~50ppm
Sulphur Dioxide	0~10ppm
Nitrogen Dioxide	0~10ppm
Hydrogen	0~2000ppm
Chlorine	0~10ppm
Hydrogen Cyanide	0~25ppm
Nitrogen Monoxide	0~100ppm
Hydrogen Chloride	0~10ppm
Ammonia	0~100ppm
Ozone	0~2ppm
Ethylene Oxide	0~25ppm
Flammable	0~100LEL